

□ Slimdrive SL-BO

□ TSA 360 NT-BO

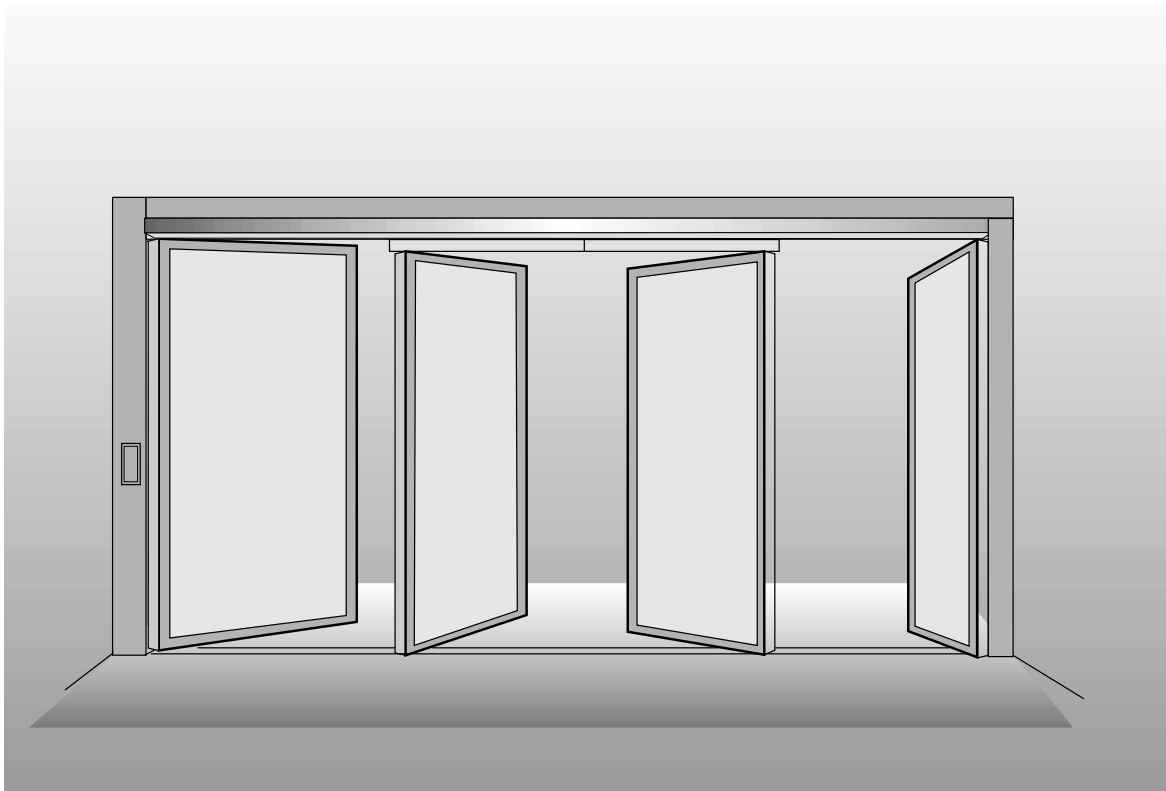

Supplemental Installation Instructions

in conjunction with

- Pre-installation, installation and service instructions for the Slimdrive SL, Mat. No. 108722
- Pre-intallation, installation and service instructions for the TSA 360 NT, Mat. No. 108758



Id. No. 116058



Mat.-Nr. 112692

Valid with software version DCU1 V1.2 and up

Contents

1	Safety precautions	4
2	Overview	6
2.1	Diagrams	6
2.2	Tools	7
2.3	Torques	7
2.4	Components and modules	7
3	Mounting	8
3.1	Preparations to be made by the customer	8
3.2	Installation	8
3.3	Installing floor guide rail	9
3.4	Installing side element	10
3.5	Aligning side element	11
3.6	Aligning compensation rail	12
3.7	Installing drive (SL-BO only)	13
3.8	Installing locking device (optional)	14
3.9	Installing door leaves	14
3.10	Setting lock (optional)	19
4	Breaking out of leaves and side elements	21
4.1	Setting disengaging forces	21
4.2	Checking panic function	21
5	Additional installation	22
6	Fault elimination	23
	EC-Declaration of Conformity TSA 360NT-BO	25
	EC-Declaration of Conformity Slimdrive SL-BO	27

Key to symbols

 Means "operation to be carried out"

 Means "important note"

 Means "additional information"



Indicates parts of the text that must be read and observed.
Failure to observe this information may result in injuries and damage!



Danger of electric shock!

1 Safety precautions

- Intended use** The **Slimdrive SL-BO** and **TSA 360 NT-BO** are only suitable for use
- in dry rooms
 - in automatic door systems for horizontally moved door leaves
 - in entrances and interior areas of pedestrian traffic in commercial plants and public areas

The **Slimdrive SL-BO** and **TSA 360 NT-BO** may not be used as fire or smoke protection doors.

The **Slimdrive SL-BO** and **TSA 360 NT-BO** are approved for use in escape and rescue routes. When the system is not locked, the sliding doors and the side elements could swing open in the exiting direction from any position. The side elements are also forced to swing open here.

- Safety precautions** The prescribed installation, maintenance and repair work must be performed by properly trained personnel authorised by GEZE.
- The country-specific laws and regulations are to be observed during safety-related tests.
- GEZE shall not be liable for injuries or damage resulting from unauthorised modification of the equipment, and the approval for use in escape and rescue routes is voided when unauthorised changes are made.
- GEZE is not liable if products from other manufacturers are used with GEZE equipment.
- Only original GEZE parts may be used for repair and maintenance work as well.
- The connection to the power supply must be made by a qualified electrician. Perform the power connection and equipment earth conductor test in accordance with VDE 0100 Part 610.
- Use a customer-accessible 10-A overload cut-out as the line-side disconnecting device.
- In accordance with Machine Directive 98/37/EC, a danger analysis must be performed and the door system identified in accordance with the CE Identification Directive 93/68/EEC before commissioning the door system.
- Observe the latest versions of guidelines, standards and country-specific regulations, in particular:
- BGR 232 "Guidelines for power-operated windows, doors and gates"
 - VDE 0100, Part 610 "Installation of high-voltage systems with nominal voltages up to 1,000 V"
 - DIN EN 60335-2-103 "Safety of electrical devices for home use and similar purposes; Special requirements for drives for gates, doors and windows"
 - AutSchR "Directive for automatic windows, doors and gates"
 - Accident-prevention regulations, especially BGV A1 "General regulations" and BGV A2 "Electrical systems and equipment"

- Safety-conscious working** Secure workplace against unauthorised entry.
- Watch swinging area of long system parts.
- Never carry out work with a high safety risk (e.g. installing the drive, hood or door leaf) while alone.
- Secure hood/drive shrouding against falling.

Use only cables prescribed in the interconnection diagram. Lay screening in accordance with the connection diagram.

Secure loose, internal drive cables with cable ties.

Before working on the electrical system:

- disconnect the drive from the 230 V mains network and check to ensure that it is not supplied with power.
- disconnect the controller from the 24 V battery.
- note that if an uninterruptible power supply (UPS) is used, the system will still be supplied with power despite the fact that the power supply is disconnected.

Always use insulated wire-end ferrules for wire cores.

Attach safety labels to glass leaf doors (Mat. No. 081476).

Danger of injury by opened drive. Hair, clothing, cables etc. can be pulled in by rotating parts!

Danger of injury by unsecured pinching, impact, shearing or drawing-in spots!

Danger of injury by broken glass!

Danger of injury by sharp edges in the drive!

Danger of injury during installation by freely moving parts!

Inspection of installed system

Measures for security and prevention of pinching, impact, shearing or drawing-in spots:

- Check the functioning of safety sensors and motion detectors.
- The detection field of the motion detector in the exiting direction must cover the opening width x 1.5 m in front of the door.
- The motion detector in the exiting direction (see AutSchR) must detect people moving faster than 0.1 m/s.
- Check earth connection to all metal parts which can be touched.

Environmentally-conscious working

When disposing of the door system, separate the different materials and have them recycled.

Do not dispose of batteries and storage cells with household refuse.

Comply with the statutory regulations when disposing of the door system and the batteries and storage cells.

2 Overview

2.1 Diagrams

Slimdrive SL-BO

Number	Type	Designation
70485-ep51	Installation diagram	Slimdrive SL-BO (DCU1) with swivelling side elements
70485-ep35 Pg. 1	Installation diagram	Arrangement diagram for accessory carrier, 2-leaf
70485-ep35 Pg. 2	Installation diagram	Arrangement diagram for accessory carrier, 1-leaf
70485-9-9801 Pg. 1	Installation instructions	Slimdrive SL-BO door leaves; 2-leaf left closing, 1-leaf right closing
70485-9-9801 Pg. 2	Installation instructions	Slimdrive SL-BO door leaves; 2-leaf right closing, 1-leaf left closing
70485-9-9803 Pg. 1	Installation instructions	Left side element, Slimdrive SL-BO
70485-9-9803 Pg. 2	Installation instructions	Right side element, Slimdrive SL-BO
70485-0-005	Block diagram	Slimdrive SL-BO drives (DCU1)
70485-9-9814	Installation instructions	Lock info sheet
70484-9-9848	Pre-installation, installation and service instructions	Slimdrive SL, Slimdrive SL-FR 2M

TSA 360 NT-BO

Number	Type	Designation
70485-ep50	Installation diagram	TSA 360 NT-BO with swivelling side elements
70485-9-9800 Pg. 1	Installation instructions	TSA 360 NT-BO door leaves; 2-leaf left closing, 1-leaf right closing
70485-9-9800 Pg. 2	Installation instructions	TSA 360 NT-BO door leaves; 2-leaf right closing, 1-leaf left closing
70485-9-9802 Pg. 1	Installation instructions	Left side element, TSA 360 NT-BO
70485-9-9802 Pg. 2	Installation instructions	Right side element, TSA 360 NT-BO
70485-0-004	Block diagram	TSA 360 NT-BO drives (DCU1)
70499-9-0950	Pre-installation, installation and service instructions	TSA 360 NT/TSA 360 NT-FR 2M

Slimdrive SL-BO and TSA 360 NT-BO

Number	Type	Designation
70484-9-9889	Supplementary connection diagram	BO DCU1
70485-9-9810	Installation instructions	Floor guide rail info sheet
70484-9-9847	Terminal connection diagram	DCU1

2.2 Tools

Tool	Size
Tape measure	
Marking pen	
Torque spanner	
Allen key	2 mm, 2.5 mm, 3 mm, 5 mm, 6 mm
Open-ended spanner	8 mm, 10 mm, 13 mm
Screwdriver set	up to 6 mm
Pin punch	3 mm with point length = 60 mm
Side-cutting pliers	
Crimping pliers for cables	
Wire stripper	
Multimeter	

2.3 Torques

See block diagram

2.4 Components and modules

See block diagram for components and modules

3 Mounting

3.1 Preparations to be made by the customer



Check the preparations made by the customer to ensure proper mounting:

- Type and loading capacity of the facade construction or sub-construction
- Levelness of the mounting surface
- Requirements of the interconnection diagram

3.2 Installation



- Secure workplace against unauthorised entry.
- Always perform work with a 2nd technician.
- Use stepladder or stepstool.
- Keep inside area of runner clean.
- Spacing between upper edge of carrier or runner and ceiling structure: min. 15 mm (see diagram below).

TSA 360 NT-BO:

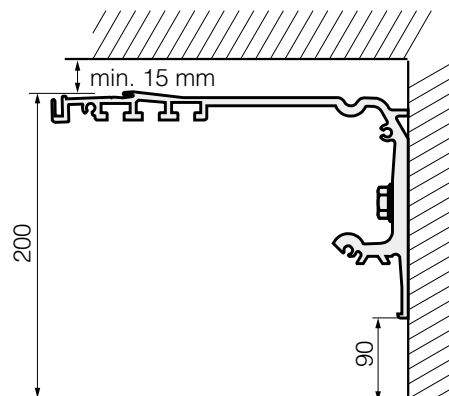

Slimdrive SL-BO:

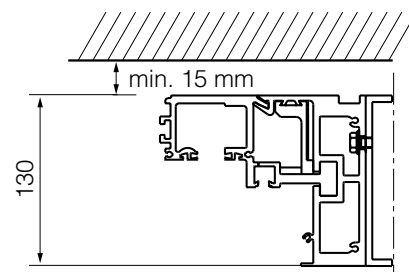

3.2.1 Installing SL-BO drive

Installing profiles

1. Drill holes according to the local conditions (see installation diagram); use carrier as drilling template if necessary.
2. Prepare cable routing in accordance with local conditions, for example:
 - Hold free (right) end piece on left side of carrier profile and copy to cable gland.
 - Remove carrier profile at marked position.
3. Insert and position accessory of the carrier profile (see installation diagram).
4. Secure side plates or mounting plates at the carrier profile.
5. Only for **post/bolt lock design**:
Align carrier profile with lower edge of bolt lock and screw it down.
For **wall installation** only:
Align carrier profile at clear alleyway and screw it down (see installation diagram).
For **cantilever installation** only:
Install carrier with mounting plates (see installation diagram).

3.2.2 Installing TSA 360 NT-BO drive

1. Drill holes according to the local conditions (see installation diagram); use runner as drilling template if necessary.
2. Prepare cable routing in accordance with local conditions.
3. Insert and position accessory of side element attachment in runner profile.
4. For **wall installation** only:
Secure side plates at the runner.
For **cantilever installation** only:
Fasten mounting plates at carrier.
5. For **wall installation** only:
Screw on runner.
For **cantilever installation** only:
Install carrier with mounting plates.

3.3 Installing floor guide rail

1. Align floor guide rail with the plumb bob on the raw floor (see installation diagram) and fasten.
2. Cover floor guide rail before pouring in the ready-mix concrete.

3.4 Installing side element

1. Align wall rail vertically (see installation diagram) and fasten.

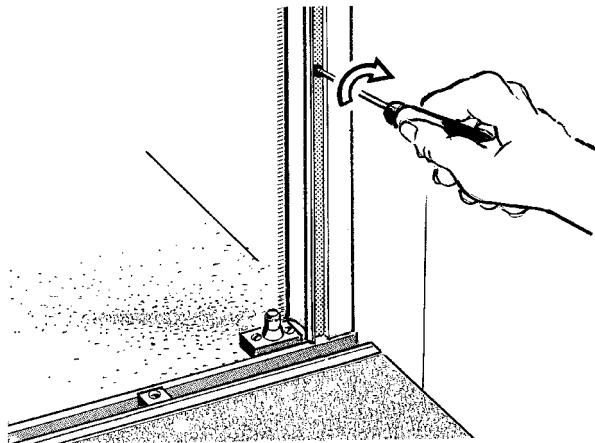

2. Insert compensation rail into the wall rail and fasten.
3. Position side element with retaining rail (see installation diagram).

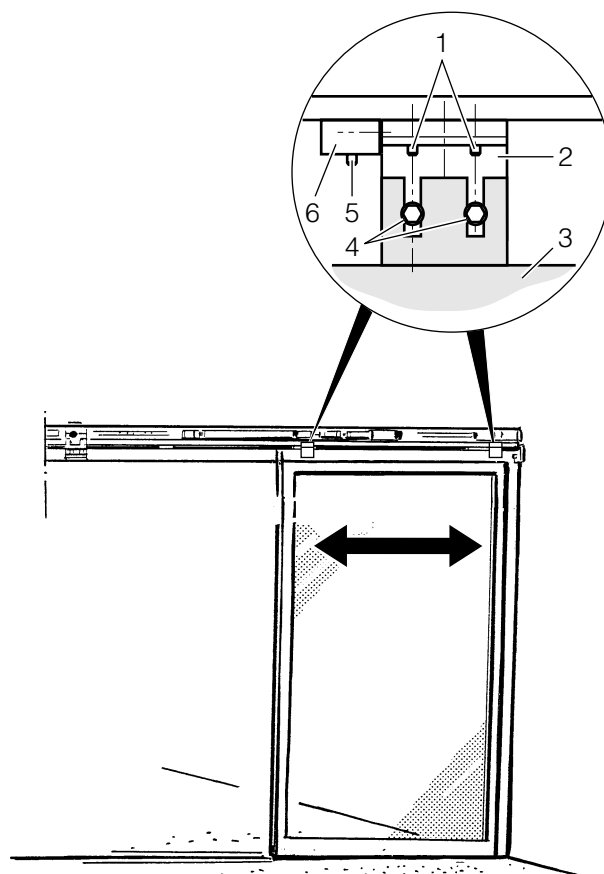

4. Loosen clamping screws (1) of the side element attachment (2) and screw (5) of the operating component (6).
5. Slide side element attachment (2) to the point determined and align it there.

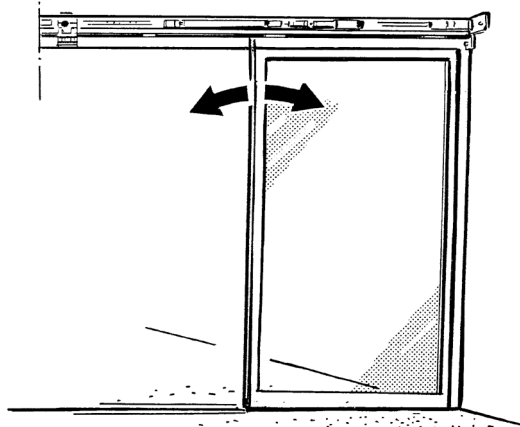

6. Tighten screws (1 and 5) again.
7. Screw side element (3) to the side element attachments (2) with screws (4).

3.5 Aligning side element

Alignment of the side elements occurs via the side element attachment (2) and the operating component (6).

1. Loosen clamping screws (1) at both side element attachments (2).
2. Align side elements (3) vertically.
3. Fine-tune with Allen screw (7) of the operating component (6) if necessary.

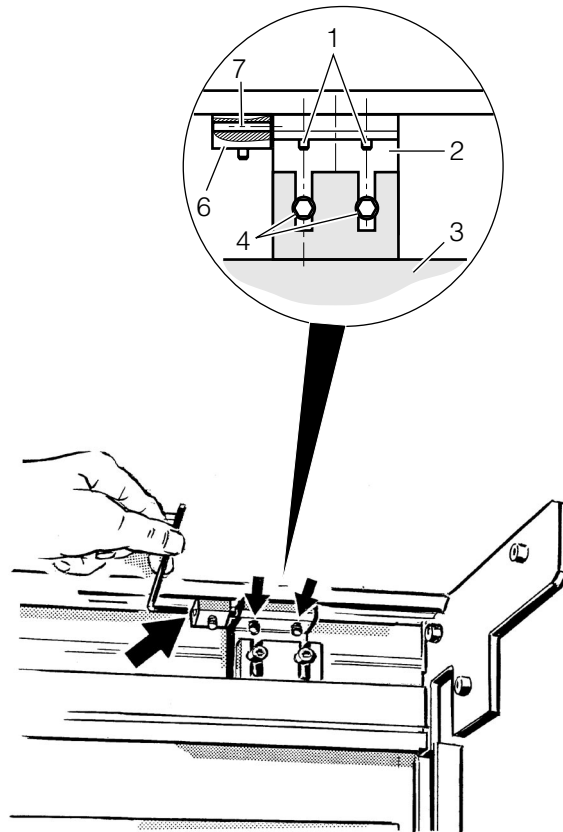

4. Tighten clamping screws (1) again.

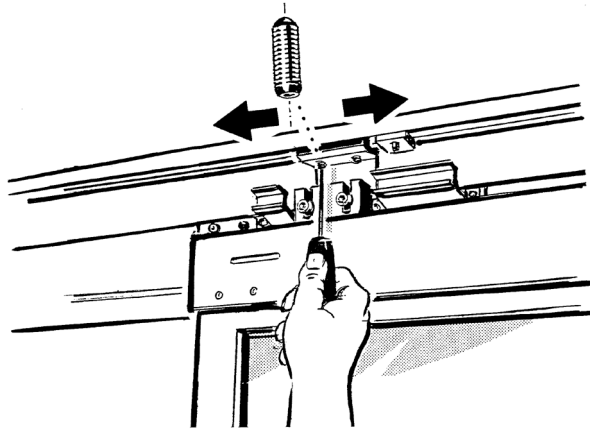

3.6 Aligning compensation rail

1. Slide compensation rail on the side rotation strip until the sealing brushes make contact.
2. Secure compensation rail with setscrews.

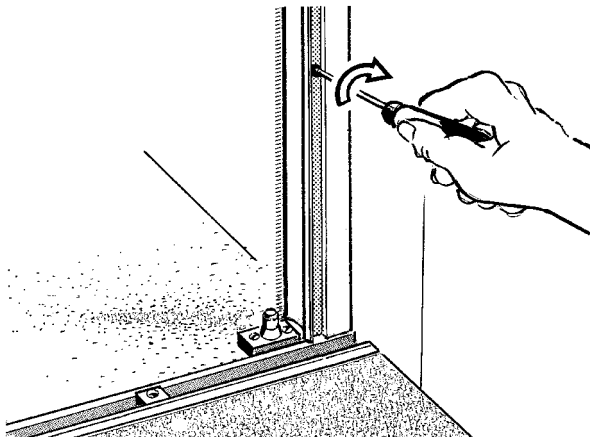

3.7 Installing drive (SL-BO only)

1. Position clamping strips (2) (see installation diagram) and fasten them at an angle with setscrews (1).

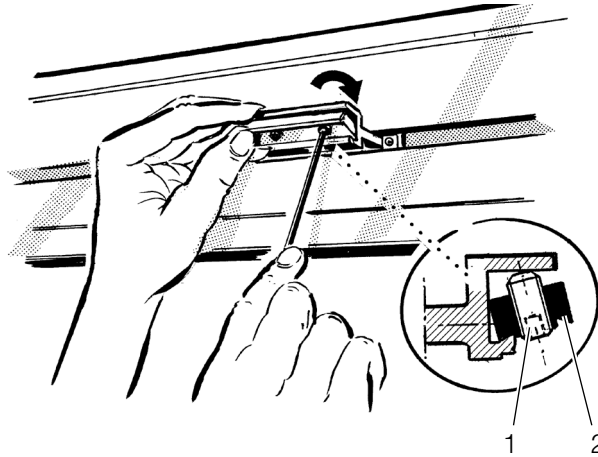

2. Hang and position drive in carrier.
3. Loosen setscrews (1) and brace clamping strips (2) straight.

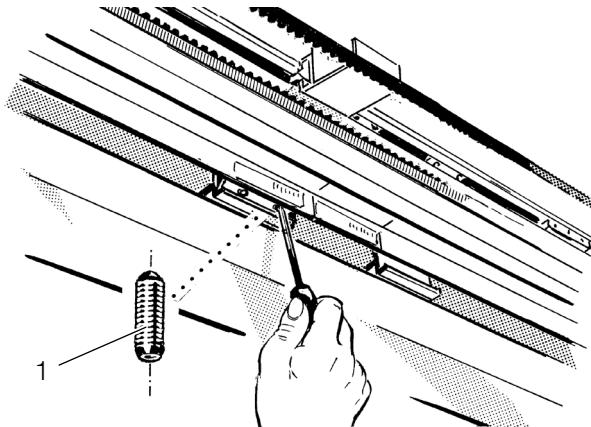

3.8 Installing locking device (optional)



With 2-leaf systems, remove the adapter for the seating of the lock.

1. Loosen setscrew M6 (1) and push clamping links (2) together.

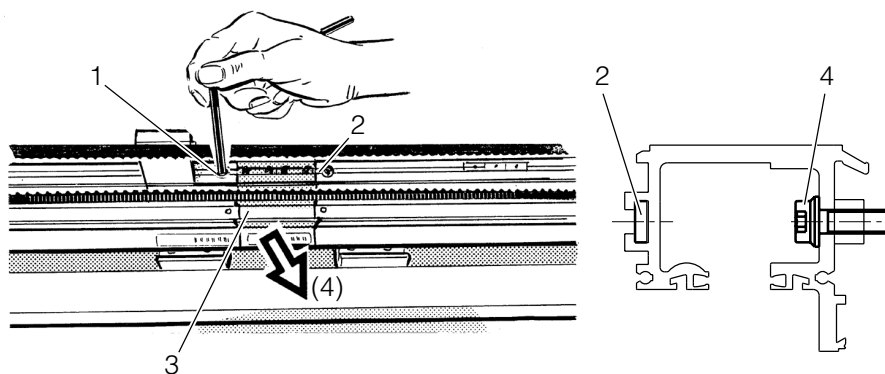

2. Remove cap screws M8 (4).
3. Remove adapter (3).

Inserting lock

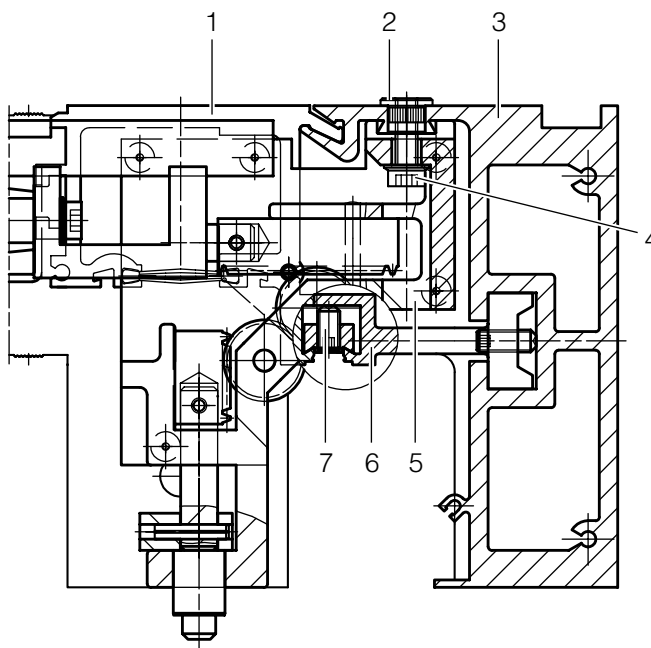

1. Guide/press in nut (2) for lock into the intended holes in the carrier profile (3).
- For 2-leaf systems:
2. Install drive (1).
 3. Use setscrew (7) to brace drive with the support profiles (6).
 4. Insert lock (5) and screw down with Allen screw (4).

3.9 Installing door leaves

3.9.1 Hanging door leaves (TSA 360 NT-BO)

- Hang door leaves (2) with door leaf carrier (3) in roller carriage (1).

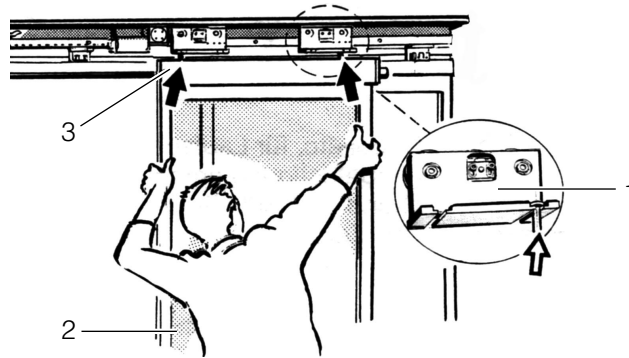

Setting distance between door leaves and finished floor



The door leaves (2) must be 7 mm from the finished floor (4).

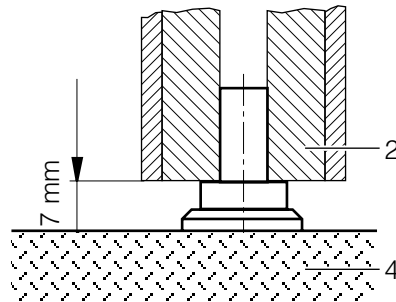

- Loosen nuts (6) and (7).

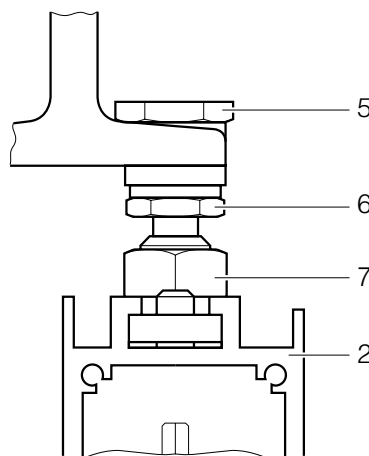

- Set distance to finished floor (4) to 7 mm with adjustment screw (5).
- Balance door leaf carriers (3) horizontally with adjustment screw (5).
- Tighten nuts (6) and (7) again.

3.9.2 Hanging door leaves (Slimdrive SL-BO)

- ⇨ Hang door leaves (3) with door leaf carrier (1) in roller carriage (2).

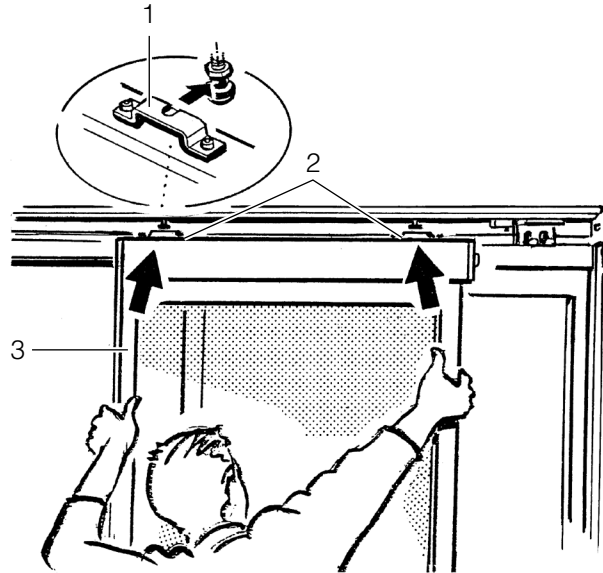

Setting distance between door leaves and finished floor



The door leaves (1) must be 7 mm from the finished floor (2).

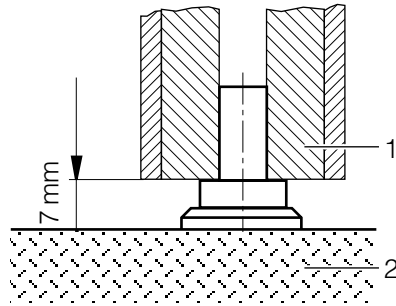

1. Loosen nuts (3) at suspension bolts.

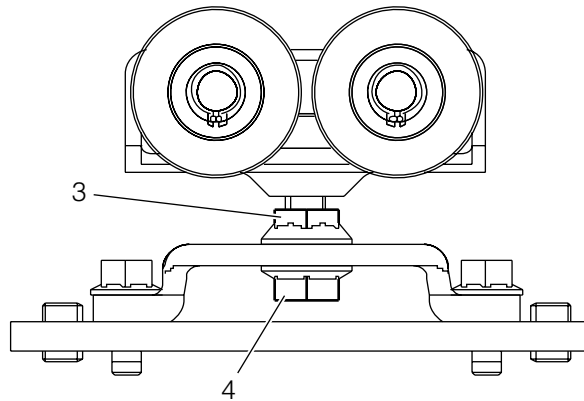

2. Set the distance to the finished floor to 7 mm at the hexagon (4) of the suspension bolts.
3. Align door leaf carrier horizontally with the suspension bolts.
4. Tighten nuts (3) at suspension bolts again.

Adjusting door leaves vertically



Do not brace door. It must be possible to engage door easily (see installation diagram).

1. Swing door leaf open slightly.

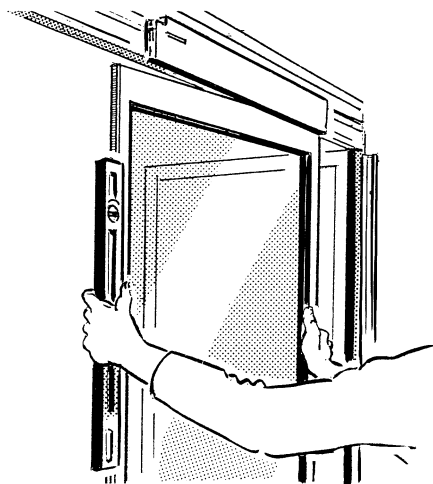

2. Adjust door leaf with setting screw (1) in bracket support of the door leaf carrier. Anticlockwise rotation means that the lower outer door edge is lifted.

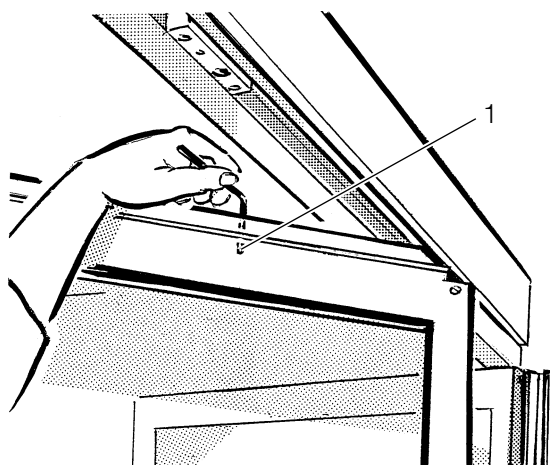

A non-visible mounted floor roller in the lower outer corner of the leaf limits lowering of the leaf when swinging open to approx. 3–4 mm. Depending on the ground conditions (e.g. a grate), a plastic slide piece can be mounted in the same spot on the door.

3. Engage leaf and side element and close door.

The lock must be unlocked. The side strips of the leaf and side element must now move in a parallel fashion.

3.9.3 Setting buffer

1. Place the clamp (1) in the floor guide rail approx. 5 mm from the floor guide in the open position and fasten it.

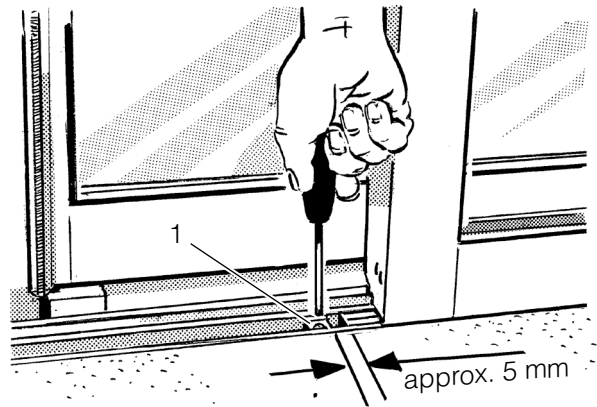

2. Open and close the doors manually.
3. Check proper running and buffer positioning and adjust if necessary.

3.10 Setting lock (optional)

Adjusting TSA 360 NT-BO longitudinally



The lock is preset ex-works.

1. Loosen setscrews (1) and adjust lock.
2. Tighten setscrews (1) again.

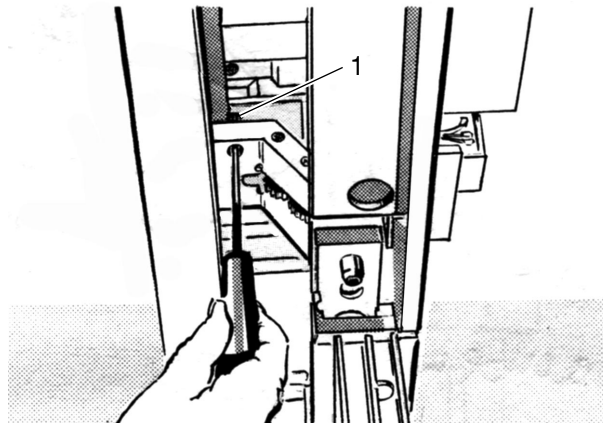

With 2-leaf BO systems: Set close position to the centre of the pass-through width.

Setting close position with TSA 360 NT-BO drive

1. Engage door leaf and side elements and close door.
2. Loosen driver screws.
3. Align leaf to centre of pass-through width and lock manually.
4. Tighten driver screws.
5. Readjust end buffer if necessary.

Setting close position with SL-BO drive

1. Loosen toothed-belt lock at the long driver.
2. Align leaf to centre of pass-through width and lock manually.
3. Refasten toothed-belt lock at the long driver.
4. Readjust end buffer if necessary.

Setting lock bolts



The lock bolts must be submerged when the leaves are closed and in the locked position up to the bush base of the locking bolts on the leaves.

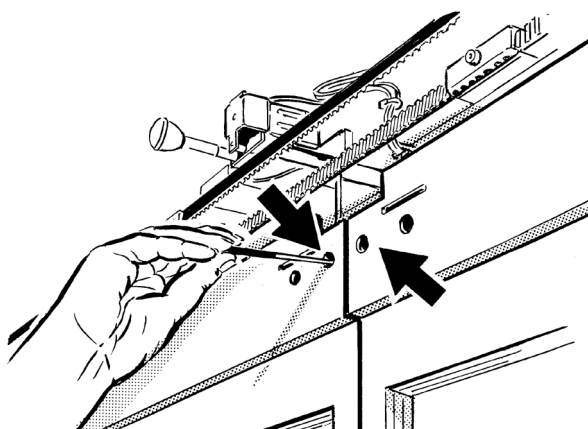

1. Loosen clamping screws of the locking bolts.
The bolts lie in the bush base due to their own weight.
2. Tighten clamping screws again.
3. Check functioning of lock.

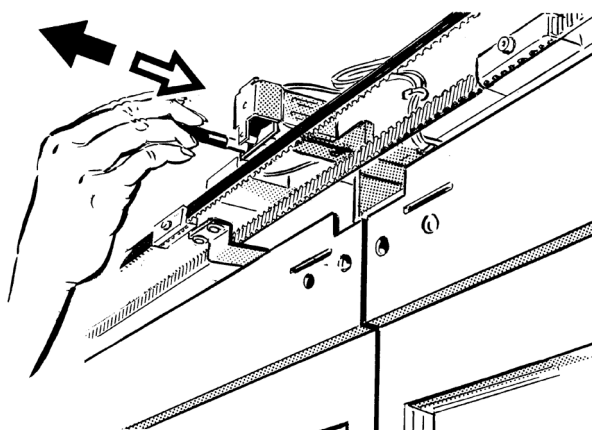

4 Breaking out of leaves and side elements



The motor switches off if at least one door/side element breaks out from any door position.

4.1 Setting disengaging forces

- Set the disengaging force/retaining force for each leaf and each side element (see installation diagram).
- The disengaging force may be max. 220 N.
- Leaves and side elements may not disengage by themselves in normal operation.

4.2 Checking panic function

Check manual disengaging force in each close position (closed, half open, open). The disengaging force per leaf or side element may not exceed 220 N.

5 Additional installation

Additional installation, connection and commissioning tasks are found in the pre-installation, installation and service instructions of the respective drives, i.e. TSA 360 NT or Slimdrive SL.

6 Fault elimination

Fault	Cause	Solution
Door leaves bind	Space to floor insufficient	⇨ Set space to floor (7 mm) (see Section 3.9)
Disengaging forces too high (> 220 N) or too low (wind pressure, suction).	Incorrect disengaging force setting	⇨ Loosen or tighten engaging elements (see installation diagram)
Door leaf scrapes the side element	Space at side insufficient	⇨ Correct hang at top to achieve a side spacing of 3.5 mm
Lock jams	Locking bolt has no space in lock bush	⇨ Adjust lock (Section 3.10)
Lock fault message	Locking bolts are not submerged	⇨ Readjust locking position/door leaf (Section 3.10)
Motor does not switch off when one or both side elements/leaves swing open	Break-out sensors set incorrectly or are defective	⇨ Adjust break-out sensors, replace if necessary
Motor does not switch on with engaged side elements/leaves	Break-out sensors set incorrectly or are defective	⇨ Adjust break-out sensors, replace if necessary
	Switching distance set incorrectly	⇨ Set switching distance correctly
Side element can be swung open manually in close position of the leaf	Side strips of leaf and side element not congruent	⇨ Readjust centre of closing system
Door leaf scrapes side element or has too much space on the side. Leaves do not close fully	Leaf and side element do not engage.	⇨ Check engagement position



EG-Konformitätserklärung EC-Declaration of Conformity CE-Déclaration de conformité

Hersteller:
(Manufacturer, Fabricant)

GEZE GmbH
Reinhold-Vöster-Str. 21–29
D-71229 Leonberg

Produktbezeichnung:
(Product identifier,
Désignation du produit)

automatische Schiebetürantriebe
(automatic sliding door drives/
systèmes automatiques pour porte coulissante)

GEZE TSA 360 NT, TSA 360 NT-FR 2M, TSA 360 NT-BO

Erklärung (Declaration, Déclaration):

Die genannten Antriebe sind in alleiniger Verantwortung des o.g. Herstellers entwickelt, konstruiert und gefertigt in Übereinstimmung mit folgendenden Richtlinien und Normen.

The above drives are under the sole responsibility of the above manufacturer developed, designed and manufactured in accordance with the following directives and standards.

Les produits mentionnés sont développés, construits es fabriqués en propre responsabilité du fabricant susnommé en respectant suivantes.

EU-Richtlinien (EU-Directives, Directives UE):

- EMV-Richtlinie 89/336/EWG in der Fassung 93/31/EWG (EMV Directive, Directive CEM)
- Niederspannungsrichtlinie 73/23/EWG in der Fassung 93/68/EWG.
(Low Voltage Directive in the version, Directive relative à la basse tension, version).

Europäische Normen (European Standards/Normes européennes):

- EN 55011
- EN 60335-1
- EN 61000-6-2
- EN 60950



Hermann Alber
Geschäftsführer

Leonberg, den 21. Oktober 2005



EG-Konformitätserklärung EC-Declaration of Conformity CE-Déclaration de conformité

Hersteller:
(Manufacturer, Fabricant)

GEZE GmbH
Reinhold-Vöster-Str. 21–29
D-71229 Leonberg

Produktbezeichnung:
(Product identifier,
Désignation du produit)

automatische Schiebetürantriebe
(automatic sliding door drives/
systèmes automatiques pour porte coulissante)

**GEZE Slimdrive SL, GEZE Slimdrive SL-FR 2M,
GEZE Slimdrive SL-BO**

Erklärung (Declaration, Déclaration):

Die genannten Antriebe sind in alleiniger Verantwortung des o.g. Herstellers entwickelt, konstruiert und gefertigt in Übereinstimmung mit folgendenden Richtlinien und Normen.

The above drives are under the sole responsibility of the above manufacturer developed, designed and manufactured in accordance with the following directives and standards.

Les produits mentionnés sont développés, construits es fabriqués en propre responsabilité du fabricant susnommé en respectant suivantes.

EU-Richtlinien (EU-Directives, Directives UE):

- EMV-Richtlinie 89/336/EWG in der Fassung 93/31/EWG (EMV Directive, Directive CEM)
- Niederspannungsrichtlinie 73/23/EWG in der Fassung 93/68/EWG.
(Low Voltage Directive in the version, Directive relative à la basse tension, version).

Europäische Normen (European Standards/Normes européennes):

- EN 55011
- EN 60335-1
- EN 61000-6-2
- EN 60950



Hermann Alber
Geschäftsführer

Leonberg, den 21. Oktober 2005

GEZE GmbH
P.O. Box 1363
71226 Leonberg
Germany

GEZE GmbH
Reinhold-Vöster-Str. 21–29
71229 Leonberg
Germany
Tel. +49 (0) 71 52-2 03-0
Fax +49 (0) 71 52-2 03-310

GEZE Online:
www.geze.com

GEZE Branches

Germany

GEZE GmbH

Niederlassung Nord/Ost
Bühningstr. 8
13086 Berlin (Weissensee)
Tel. +49 (0) 30-47 89 90-0
Fax +49 (0) 30-47 89 90-17
E-Mail: berlin.de@geze.com

GEZE GmbH

Niederlassung West
Nordsternstraße 65
45329 Essen
Tel. +49 (0) 2 01-8 30 82-0
Fax +49 (0) 2 01-8 30 82-20
E-Mail: essen.de@geze.com

GEZE GmbH

Niederlassung Mitte
Adenauerallee 2
61440 Oberursel (b. Frankfurt)
Tel. +49 (0) 61 71-6 36 10-0
Fax +49 (0) 61 71-6 36 10-1
E-Mail: frankfurt.de@geze.com

GEZE GmbH

Niederlassung Süd
Reinhold-Vöster-Straße 21–29
71229 Leonberg
Tel. +49 (0) 71 52-2 03-5 94
Fax +49 (0) 71 52-2 03-4 38
E-Mail: leonberg.de@geze.com

Subsidiaries

Germany

GEZE Sonderkonstruktionen

GmbH
Planken 1
97944 Boxberg-Schweigern
Tel. +49 (0) 79 30-9 2 94-0
Fax +49 (0) 79 30-9 2 94-10
E-Mail: sk.de@geze.com

GEZE SERVICE GmbH

Reinhold-Vöster-Str. 25
71229 Leonberg
Tel. +49 (0) 71 52-92 33-0
Fax +49 (0) 71 52-92 33-60
E-Mail: info@geze-service.com

GEZE SERVICE GmbH

Niederlassung Berlin
Bühningstr. 8
13086 Berlin (Weissensee)
Tel. +49 (0) 30-47 02 17-30
Fax +49 (0) 30-47 02 17-33

Asia

GEZE Asia Pacific Ltd.

Unit 630, Level 6, Tower 2
Grand Central Plaza
138 Shatin Rural Committee Road
Shatin, New Territories
Hong Kong
Tel. +852 (0) 23 75 73 82
Fax +852 (0) 23 75 79 36
E-Mail: info@geze.com.hk

GEZE Industries

(Tianjin) Co., Ltd.
Shuangchenzhong Road
Beichen Economic Development
Area (BEDA)
Tianjin 300400, P. R. China
Tel. +86 (0) 22-26 97 39 95-0
Fax +86 (0) 22-26 97 27 02
E-Mail: geze@public1.tpt.tj.cn

GEZE Industries

(Tianjin) Co., Ltd.
Branch Office Shanghai
Dynasty Business Center
Room 401–402
No. 457 WuRuMuQi North Road
200040 Shanghai, P. R. China
Tel. +86 (0) 21 52 34 09-60/-61/-62
Fax +86 (0) 21 52 34 09-63
E-Mail: gezesh@geze.com.cn

GEZE Industries

(Tianjin) Co., Ltd.
Branch Office Guangzhou
Room 1113, Jie Tai Plaza
218–222 Zhong Shan Liu Road
510180 Guangzhou, P. R. China
Tel. +86 (0) 20 81 32 07-02
Fax +86 (0) 20 81 32 07-05
E-Mail: gezegz@public2.sta.net.cn

GEZE Industries

(Tianjin) Co., Ltd.
Branch Office Beijing
The Grand Pacific Building
B Tower Room 201
8 A, Guanghua Road
Chaoyang District
100026 Beijing, P. R. China
Tel. +86 (0) 10 65 81 57-32/-42/-43
Fax +86 (0) 10 65 81 57-33

GEZE Asia Sales Ltd.

No. 88-1-408, East Road
Free Trade Zone of Tianjin Port
Tianjin, P. R. China
Tel. +86 (0) 22 26 97 39 95-0
Fax +86 (0) 22 26 97 27 02
E-Mail: geze@public1.tpt.tj.cn

Middle East

U.A.E.

GEZE Middle East
P.O. Box 17903
Jebel Ali Free Zone
Dubai
Tel. +971 (0) 4 88 33 112
Fax +971 (0) 4 88 33 240
E-Mail: geze@emirates.net.ae

Europe

France

GEZE France S.A.R.L.
ZAC de l'Orme Rond
RN 19
77170 Servon
Tel. +33 (0) 1 60 62 60 70
Fax +33 (0) 1 60 62 60 71
E-Mail: france.fr@geze.com

Great Britain

GEZE UK Ltd.
Blenheim Way
Fradley Park
Lichfield
Staffordshire WS13 8SY
Tel. +44 (0) 15 43 44 30 00
Fax +44 (0) 15 43 44 30 01
E-Mail: info@geze-uk.com

Italy

GEZE Italia Srl
Via Giotto 4
20040 Cambiagio (MI)
Tel. +39 (0) 02 95 06 95-11
Fax +39 (0) 02 95 06 95-33
E-Mail: italia.it@geze.it

GEZE Engineering Roma Srl

Via Lucrezia Romana 91
00178 Roma
Tel. +39 (0) 06 72 65 31 1
Fax +39 (0) 06 72 65 31 36
E-Mail: gezeroma@libero.it

GEZE Engineering Bari Srl

Via Treviso 58
70022 Altamura (Bari)
Tel. +39 (0) 080 31 15 21 9
Fax +39 (0) 080 31 64 56 1
E-Mail: gezebari@libero.it

Benelux

GEZE Benelux B.V.
Industrieterrein Kapelbeemd
Leemkuil 1
5626 EA Eindhoven
Tel. +31 (0) 40 26 29 08 0
Fax +31 (0) 40 26 29 08 5
E-Mail: benelux.nl@geze.com

Austria

GEZE Austria GmbH
Mayrwiesstraße 12
5300 Hallwang b. Salzburg
Tel. +43 (0) 662 66 31 42
Fax +43 (0) 662 66 31 42-15
E-Mail: austria.at@geze.com

Poland

GEZE Polska Sp. z o.o.
ul. Annopol 3 (Zerań Park)
03-236 Warszawa
Tel. +48 (0) 22 814 22 11
Fax +48 (0) 22 614 25 40
E-Mail: geze@geze.pl

Switzerland

GEZE Schweiz AG
Bodenackerstr. 79
4657 Dulliken
Tel. +41 (0) 62-285 54 00
Fax +41 (0) 62-285 54 01
E-Mail: schweiz.ch@geze.com

Spain

GEZE Iberia S.R.L.
Pol.Ind. EL Pla
C/Comerc, 2–22, Nave 12
08980 Sant Feliu de Llobregat
(Barcelona)
Tel. +34 (0) 9 02 19 40 36
Fax +34 (0) 9 02 19 40 35
E-Mail: iberia.es@geze.com

Scandinavia

Sweden

GEZE Scandinavia AB
Mallslingan 10
Box 7060
18711 Täby
Tel. +46 (0) 8-732 34-00
Fax +46 (0) 8-732 34-99
E-Mail: sverige.se@geze.com

Norway

GEZE Scandinavia AB avd. Norge
Postboks 63
2081 Eidsvoll
Tel. +47 (0) 639 572 00
Fax +47 (0) 639 571 73
E-Mail: norge.se@geze.com

Finland

GEZE Finland
Branch office of GEZE Scandinavia AB
Postbox 20
15871 Hollola
Tel. +358 (0) 10-400 5100
Fax +358 (0) 10-400 5120
E-Mail: finland.se@geze.com

Denmark

GEZE Denmark
Branch office of GEZE Scandinavia AB
Møllehusene 3, 3.th.
4000 Roskilde
Tel. +45 (0) 46-32 33 24
Fax +45 (0) 46-32 33 26
E-Mail: danmark.se@geze.com

Your attention is drawn to the "product liability law" defined liability to the manufacturer for his products which are contained in the main catalogue (product information, usage, misuses, product activity, product maintenance, the duty to inform and the duty to instruct). Non compliance with these conditions relieves the manufacturer from any liability.

GEZE Representative:

